

# Mounting stud 42677

## Accessory

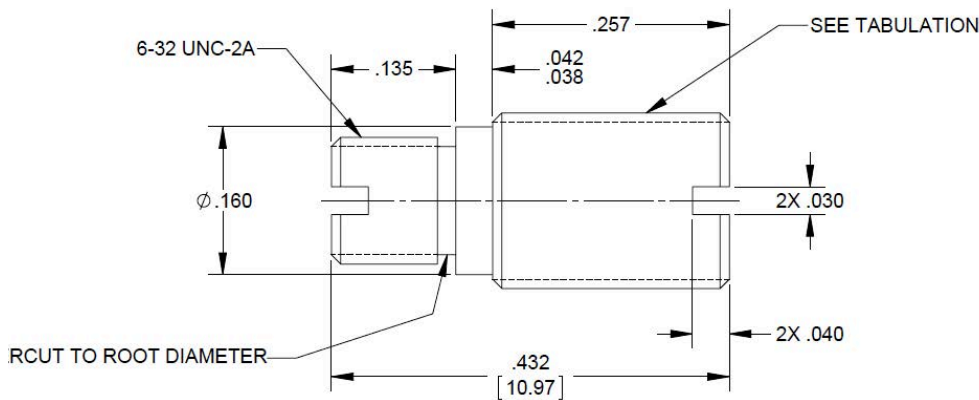

DASH NO.	THREAD
42677-1	10-32 UNF-2A
42677-2	1/4-28 UNF-2A
42677-3	M6 X 1 - 6g
42677-4	M5 X 0.8 - 6g

## Description

Mounting stud with slotted head for use with accelerometers with a 6-32 thread.

## Specifications

	42677-1	42677-2	42677-3	42677-4
Thread size, mounting side	10-32	1/4-28	M6	M5
Thread size, accel side	6-32	6-32	6-32	6-32
Material	Stainless Steel	Stainless Steel	Stainless Steel	Stainless Steel
Weight (Grams)	0.9	1.4	1.3	1.0

