

Piezoresistive accelerometer

Model 7270AM7

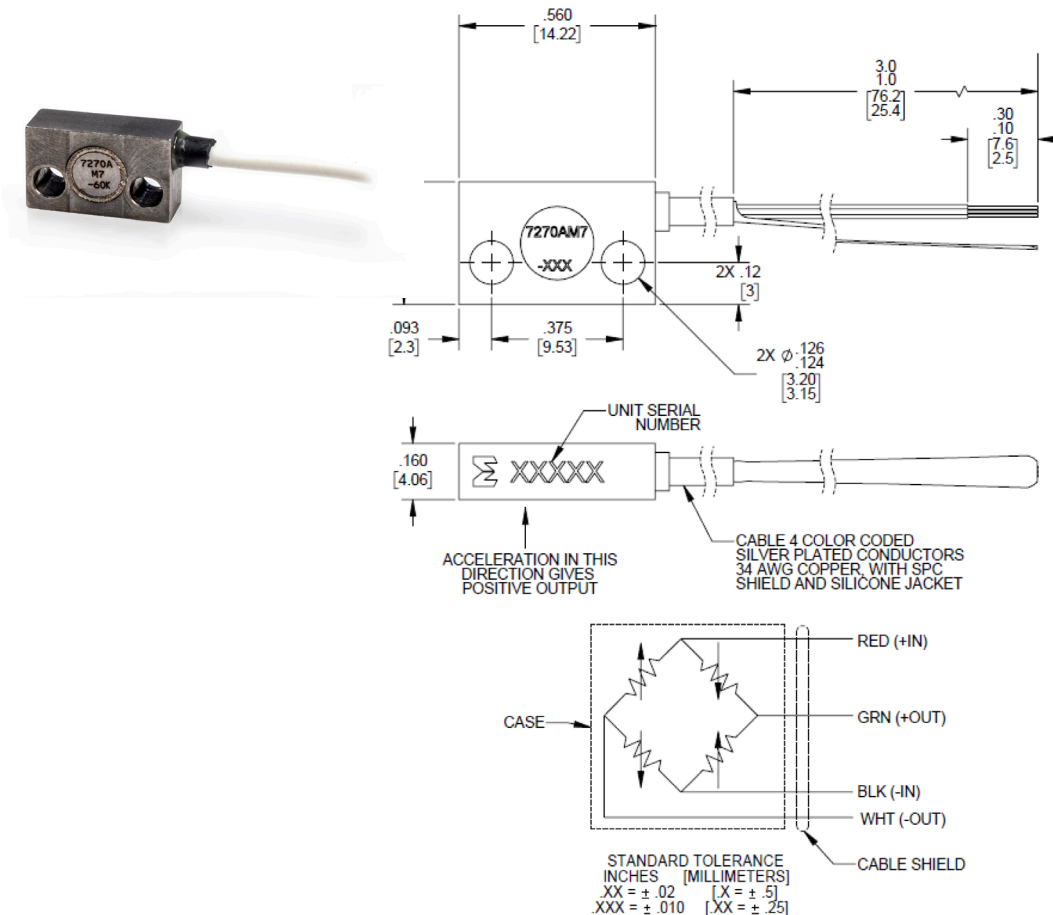

Key features

- 2K, 6K, 20K, 60K and 200K full scale ranges
- High resonance frequency for exceptional bandwidth
- Minimal zero shift after shock
- Low noise cable

The ENDEVCO® Model 7270AM7 is a family of rugged undamped piezoresistive accelerometers designed for shock measurements. The highly efficient sensing system of the 7270AM7 is sculptured from a single chip of silicon, which includes the inertial mass and strain gages arranged in a four-active-arm Wheatstone bridge circuit (patent numbers 4,498,229; 4,605,919 and 4,689,600). The extremely small size and unique construction of the element allows exceptionally high resonant frequency. On-chip balance resistors provide low zero measurand output and low thermal zero drift. The light weight flat case is designed to reduce the effect of case resonance's for optimum frequency response. The M7 modification features a low-noise cable with protective shrink tubing for superior performance on high-shock environments.

60,000 and 200,000g ranges are subject to International Traffic in Arms Regulations (ITAR), and as such a license is required for shipments outside the U.S. and other restrictions may apply.

Piezoresistive accelerometer

Model 7270AM7

Specifications

All specifications are referenced at +75°F (+24°C) and 10 Vdc, unless otherwise noted. Calibration data, traceable to National Institute of Standards and Technology (NIST), is supplied.

Dynamic characteristics	Units	2K	6K	20K	60K	200K
Linear range	g	2,000	6,000	20,000	60,000	200,000
Sensitivity min/typ [1]	μV/g	50/100	15/30	5/10	1.5/3	.5/1
Frequency response +/-5%	Hz	0 to 10,000	0 to 20,000	0 to 50,000	0 to 100,000	0 to 150,000
Natural frequency (typ)	kHz	90	180	350	700	1200
Shock limit [max]	g	10,000	18,000	60,000	180,000	200,000
Zero measureand output (max)	mV	+/-100	+/-100	+/-100	+/-100	+/-100
Transverse sensitivity (max)	%	5	5	5	5	5
Thermal zero shift [2]	mV	10	10	10	10	10
-30°F to +150°F (-34°C to +66°C)						
Thermal sensitivity shift	%/C	-0.12	-0.12	-0.12	-0.12	-0.12
Electrical characteristics						
Excitation	Vdc	2 to 12 (10 standard)				
Resistance						
input	Ω	650 ± 300				
output	Ω	650 ± 300				
Isolation resistance		100 MΩ min at 100 VDC between the sensor (leads shorted together) and cable shield or case.				
Physical characteristics						
Case material		17-4 CRES				
Weight (excluding cable)		4 grams				
Cable		(4) 34 AWG SPC, braided shield, silicone jacket, cable weight 0.10 oz/ft (2.83 g/ft)				
Mounting		4-40 high strength screws (x2) Recommended mounting torque, 8 ± 2 lbf-in (0.9 N-m)				
Environmental						
Temperature						
Operating [3]	°C (F°)	- 55 to + 121 (- 67 to + 250)				
Storage	°C (F°)	- 55 to + 121 (- 67 to + 250)				
Calibration data						
Data for sensitivity, ZMO, input and output resistance are supplied on the calibration certificate. Unless specified by the customer at time of order, the default calibration will be performed at 10.0 Vdc excitation.						

Piezoresistive accelerometer

Model 7270AM7

Accessories

Product	Description	7270AM7
EH853	[2] 4-40 high strength screws	Included
EHW265	[2] No. 4 washers	Included
7980	Triaxial mounting block	Optional
136	DC amplifier, 3-channel benchtop	Optional

Notes

1. Sensitivity measured at 5,000g, except for 2,000g model measured at 2,000g
2. Operating temperatures above 93C (200F) result in unpredictable thermal zero shift. TZS should be monitored and/or managed by auto-zeroing to insure no loss in data due to signal saturation.
3. 150°F is the maximum recommended operating temperature with 10 Vdc excitation. In applications requiring higher operating temperatures, lower excitation voltage is recommended.
4. Maintain high levels of precision and accuracy using Endevco's factory calibration services. Call Endevco's inside sales force at 866-ENDEVCO for recommended intervals, pricing and turn-around time for these services as well as for quotations on our standard products.
5. Model number definition:

7270AM7 - XXX - ZZZ

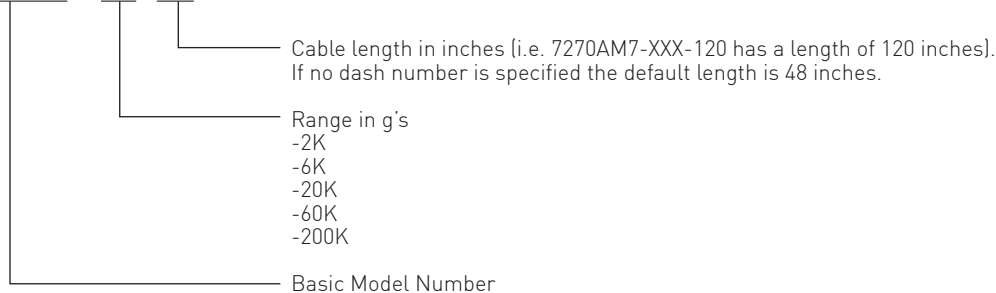

Contact

ENDEVCO

www.endevco.com

Tel: +1 (866) ENDEVCO

[+1 (866) 363-3826]