

Endevco®

Endevco model 126 3-channel PR Signal Conditioner

Instruction manual

Legacy Product Not For Sale

Contents

Safety	3
Description	4
Wiring information	5
Front panel	7
Rear panel	8
Setting up the model 126	9
Location of filter modules and Rsh resistors	12
Outline dimensions	13

Legacy Product Not For Sale

Safety

Read this manual in its entirety before operating the model 126 signal conditioner. Read all wiring and power hookup instructions and understand the requirements prior to using another manufacturer's products with the model 126. Insure that any product being interfaced with the model 126 is wired according to prevailing local safety and operational standards before operating.

The following symbols and terms may be found on the model 126 and its manuals and indicate important information.



When found on the device, this symbol indicates that the operator should refer to the manual for important instructions on the proper use of this device. When found in the manual, this symbol indicates that the reader should understand the implications contained in the text before operating the device.



This symbol indicates that a shock hazard may be present. Read the instruction manual carefully and insure that the device is wired properly and that all settings have been checked prior to applying power to the device.

The WARNING label indicates important information that should be heeded for safe and proper performance of the device.

The CAUTION label is used to indicate that damage to the power supply or equipment connected to it could occur if directions are not followed. Warranty could be invalidated if the instructions in this manual are not followed.

Disassembling the instrument



WARNING

Turn input power switch OFF before removing power cable from the instrument. Remove power cable from instrument before disassembling any part of the instrument.

Grounding



WARNING

To avoid electrical shock, the power cord protective grounding conductor must be connected to power ground.

Fuse replacement



CAUTION

For continued fire protection, replace fuse only with the specific type and rating by qualified personnel (reference manual "Rear Panel" section). Disconnect the power cord before replacing fuse.

Description

The model 126 is a new, microprocessor-controlled, 3-Channel DC signal conditioner amplifier designed to be used with bridge type or differential output accelerometers and pressure transducers. The model 126 incorporates variable gain adjustment, shunt calibration capability, and multiple excitation level settings. For various applications where specific frequency roll-off is required, the model 126 offers a variety of optional filter modules.

The model 126 utilizes a microprocessor SLEEP mode to eliminate high frequency clock noise and their associated harmonics. The microprocessor WAKES momentarily to acknowledge front panel switch depressions then goes to SLEEP immediately after processing and executing the requested function. This allows the amplifiers to operate with minimum self generated noise and provides clean, clock free amplified signals.

The model 126 uses dual 12-bit DAC's, for each channel, to autozero the input and output amplifiers for DC input signals. Input signals with magnitudes of ± 10 Vdc can be zeroed. Unzeroing the amplifier zeroes both autozero DAC's. A unique output DAC trimming routine, allows trimming the output zero to within ± 1 mVdc.

Dual 12-bit DAC's, for each channel, are also used to set amplifier gains from 0.00 to 999.9 with $\pm 0.5\%$ precision. Amplifier gains can be changed "on the fly" without damage to the instrument.

Each of the 3 amplifiers has a 150 kHz full power and a 200 kHz small signal bandwidth and can drive 10 mA into a 1 K ohm load. A low pass filter socket is provided, for each amplifier, to filter broadband noise. A variety of optional filter modules can be installed in these sockets.

The transducer excitation supplies are individually adjustable for each channel from 0.00 to 12.00 Vdc. Any setting above 12.00 Vdc will generate an excitation voltage of 12.10 Vdc. The outputs are short circuit protected and can supply up to 30 mA each. Remote sense leads are provided to eliminate errors caused by long cable lengths.

The model 126 has been CE tested for compliance to EN61326 for EMC emissions and immunity and EN61010-1:2001 for product safety.

Consult Endevco Application Engineers for associated optional filter modules and cable assemblies to mate with the model 126.

Wiring information

CH1, CH2 and CH3 (9-Pin standard D-subminiature) transducer connector

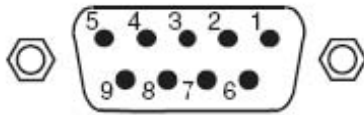

Rear Panel View

- 1 - Sense(+)
- 2 - NC
- 3 - NC
- 4 - Vin(-)
- 5 - Vin(+) Note: Vin(+) and Vin(-) are fully differential inputs
- 6 - Sense(-)
- 7 - Vexc(+)
- 8 - Vexc(-) Note: Vexc(-) is connected to analog ground
- 9 - NC

Recommended hookup for bridge type sensors

(Sense leads wired for optimum performance)

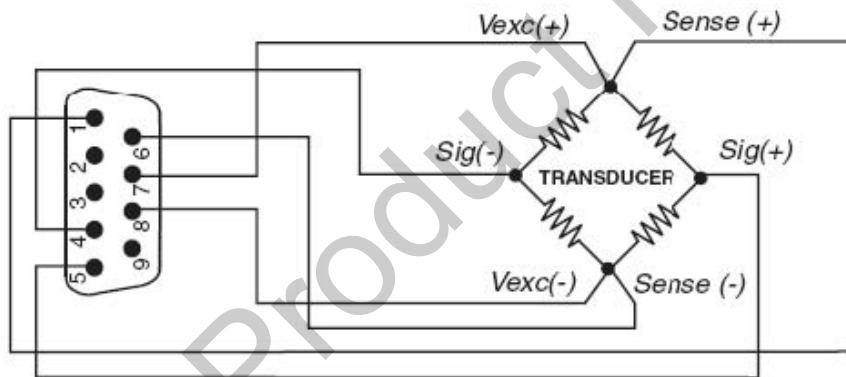

Typical hookup for bridge type sensors

(Alternate sense lead wiring)

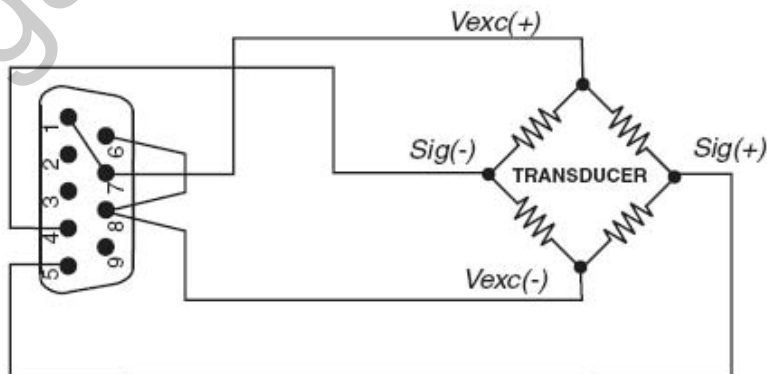

Wiring information

Hookup without any Excitation Supply or Ground Reference

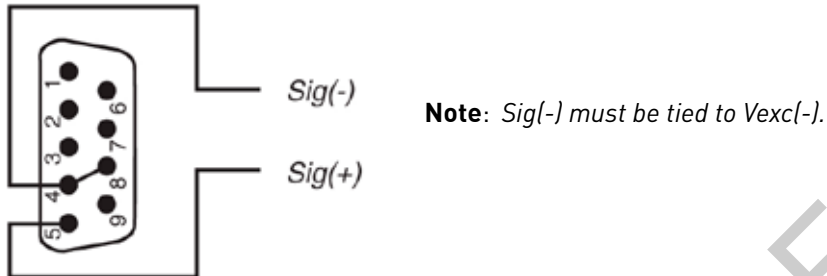

CH1, CH2 and CH3 output BNC connector (50 ohm)

Typical hookup to oscilloscope

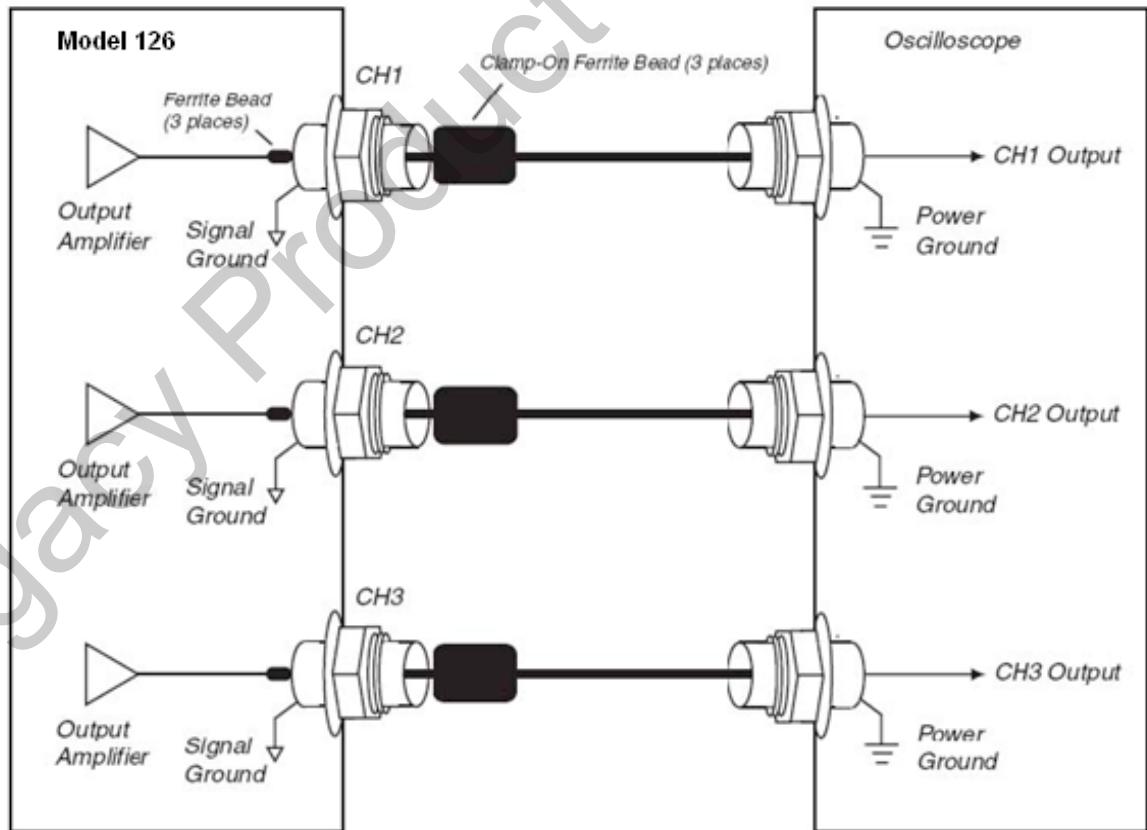

Note: The model 126 signal ground is isolated from power ground. This allows connecting the oscilloscope power ground to the 126 signal ground. To minimize high frequency EMI susceptibility, install clamp-on ferrites with frequency bands of 80 MHz to 800 MHz

Front panel

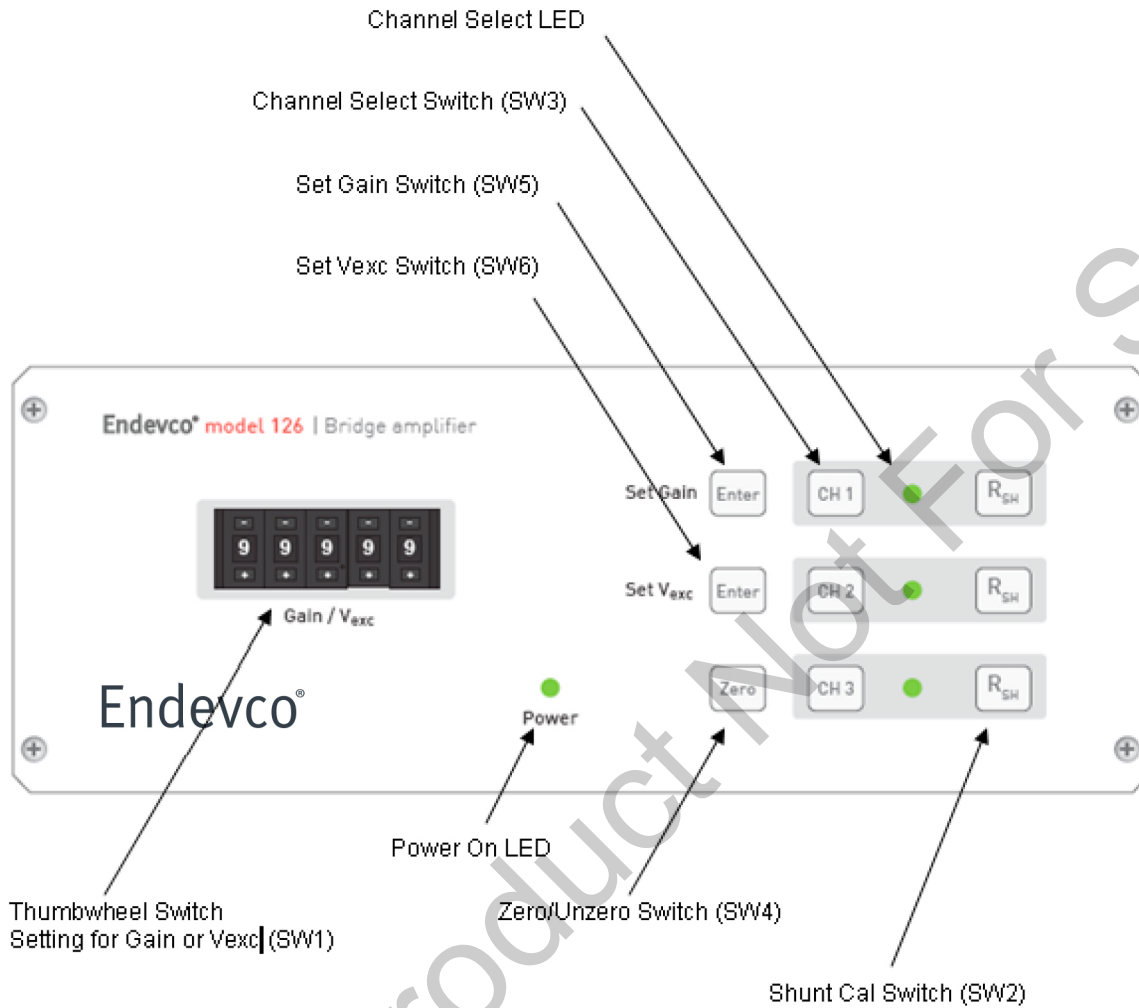

SW1 (gain / excitation)	Sets gain from 0.00 to 999.9 or Vexc from 0.00 to 12.00 Vdc
SW2 (shunt cal switch)	Activates shunt cal relay and internal shunt cal resistor
SW3 (channel select switch)	Used to select channel to update
LED1 (channel select LED)	Illuminates when corresponding channel is selected
SW4 (zero / unzero switch)	Zeroes, unzeroes, or trims zero of selected channel
SW5 (set gain switch)	Sets gain to thumbwheel switch setting of selected channel
SW6 (set Vexc switch)	Sets Vexc to thumbwheel switch setting of selected channel
LED2 (power on LED)	Illuminates when V-, 50/60 Hz input power is applied

Rear panel

! **CAUTION** Verify fuse with proper V~ and current is installed in fuseholder prior to applying AC Input Power
Voltage/Rated Current/Fuse Rating Chart

! **CAUTION** Verify fuse with proper V~ current rating and type is installed in fuseholder and Voltage Selector switch is properly set before turning on Power On/Off Switch
Power On / Off Switch

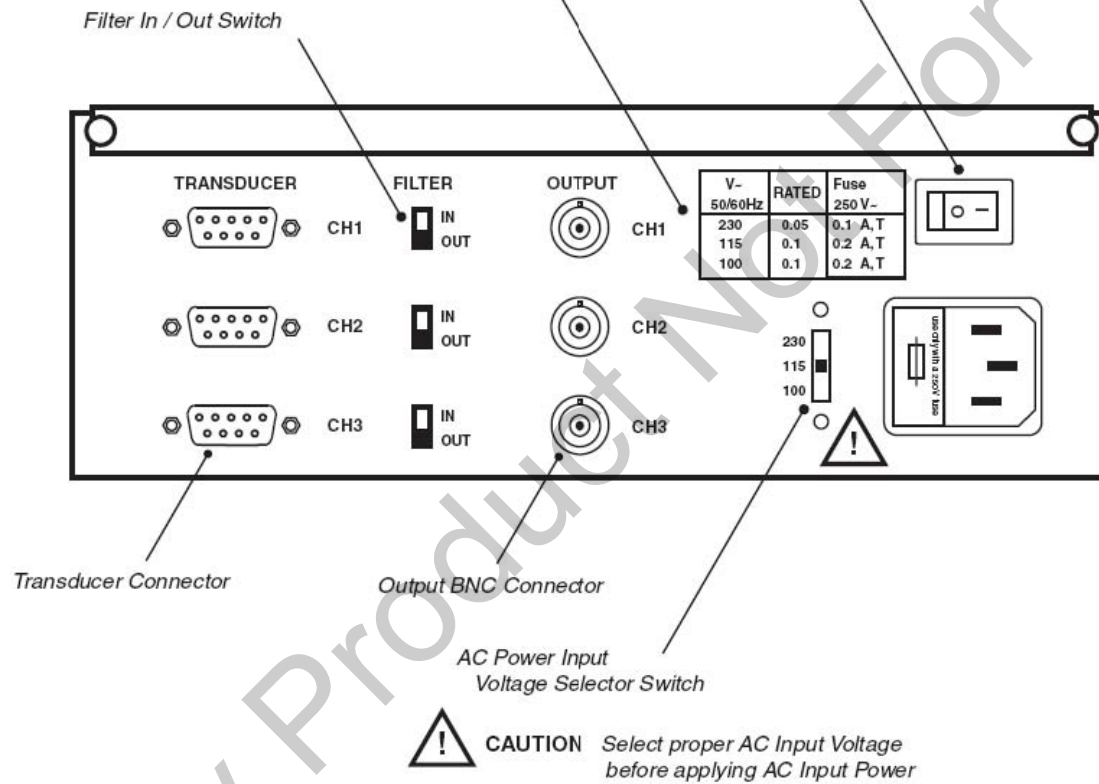

Setting up the model 126

To setup CH1, CH2 or CH3, perform the following steps in the sequence shown.

Step 1: Set Vexc

1. Set the GAIN/Vexc thumbwheel switch (SW1) to desired Vexc

Note: *If the thumbwheel switch is set to a value >12.00, Vexc will be 12.10 Vdc. For 0.00 < or = thumbwheel switch setting < or = 12.00, Vexc will be equal to the thumbwheel switch setting, when selected.*

2. Depress the channel select switch for CH1, CH2 or CH3. The appropriate channel select LED will illuminate and stay illuminated.
3. Depress the SET Vexc Switch (SW6). The channel select LED will extinguish and Vexc for the selected channel will be set to the thumbwheel switch setting.

Example: Set thumbwheel switch to 009.75. Depress CH2 switch, then the SET Vexc switch. Vexc for CH2 should be 9.75 Vdc \pm 1%. Setting the thumbwheel switch to 009.74 or 009.76 and depressing the CH2 switch then the SET Vexc switch again allows trimming of the Vexc supply.

Step 2: Set amplifier gain

1. Set the GAIN/Vexc thumbwheel switch (SW1) to desired amplifier gain.

Note: *The amplifier gain can be set anywhere from 0.00 to 999.9.*

2. Depress the channel select switch for CH1, CH2, or CH3. The appropriate channel select LED will illuminate and stay illuminated.
3. Depress the SET GAIN switch (SW5). The channel select LED will extinguish and the selected channel gain will be set to the thumbwheel switch setting.

Example: Set the GAIN/Vexc thumbwheel switch to 075.00. Depress CH2 switch, then the SET GAIN switch. CH2 gain will be set to 75.00 \pm 0.5%. Setting the thumbwheel switch to 074.99 or 075.01 and depressing CH2 switch, then the SET GAIN switch again allows trimming of the amplifier gain.

Step 3: Zero the amplifier

1. Verify the input to the appropriate channel is the desired input to be zeroed.

Note: *Any DC input signal, within the specified operating range of the amplifier can be zeroed.*

2. Depress the channel select switch CH1, CH2, or CH3. The appropriate channel select LED will illuminate and stay illuminated.
3. Depress and release the ZERO switch (SW4).

Setting up the model 126

4. The amplifier, under microprocessor control, will first zero the output of the input amplifier, then zero the output of the output amplifier. The output will be 0.00 ± 0.050 Vdc (typ).

Step 4: Trimming the zero output

Note: *Trimming allows the user to zero the output of the selected channel to within ± 1 mVDC. This trimmed value may then be stored in non-volatile memory and reapplied upon power turn on.*

1. Perform Step 3: Zero the amplifier.
2. Depress and hold depressed, the channel select switch for CH1, CH2 or CH3. The appropriate channel select LED will illuminate and stay illuminated.
3. To increment the output zero by 1 count of the output zero DAC, set the GAIN/Vexc thumbwheel switch (SW1) to "0 0 0. 0 1".

To decrement the output zero by 1 count of the output zero DAC, set the GAIN/Vexc thumbwheel switch (SW1) to "0 0 1. 0 1".

4. Depress the ZERO switch. The output zero will increment or decrement by 1 count of the output zero DAC. Successive depressions of the ZERO switch will continue to increment or decrement the output zero.

Note: *To increment the output zero by (x) counts of the output zero DAC, set the GAIN/Vexc thumbwheel switch (SW1) to "0 0 0. 0 x" and depress the ZERO switch.*

To decrement the output zero by (x) counts of the output zero DAC, set the GAIN/Vexc thumbwheel switch (SW1) to "0 0 1. 0 x" and depress the ZERO switch.

5. To save the trimmed zero value in non-volatile memory, depress and hold depressed the channel select switch again. The selected channel LED will extinguish. The trimmed zero value will be stored in non-volatile memory.

Note: *If any other channel is selected before the selected channel switch is depressed and held, the trimmed zero value will not be saved and the previously stored zero value will be used at power up.*

Setting up the model 126

Unzeroing the desired channel.

Note: *Unzeroing the desired channel sets both autozero DAC's to zero. This basically sets the amplifier to its natural zero position. The output of the amplifier is offset by its own offset voltage.*

Step 1: Unzero the amplifier

1. Depress the channel select switch for CH1, CH2 or CH3. The appropriate channel select LED will illuminate and stay illuminated.
2. Depress and hold the ZERO switch (SW4) until the appropriate channel select LED extinguishes. The selected channel amplifier is unzeroed.

Applying an internal shunt calibration resistor (Rsh) to the selected channel bridge network.

Note: *Internal solder jumpers allow for a positive or negative responding Rsh. The shunt cal resistors are removable and may be installed by the user. Reference location of filter modules and Rsh resistor in the following page.*

Step 1: Applying an internal Rsh

1. Simply depress and hold the Rsh switch for the desired channel amplifier. The shunt cal resistor is applied to the appropriate transducer bridge circuit terminals for the duration that the Rsh switch is depressed.



WARNING

Turn input power switch OFF before removing power cable from the instrument. Remove power cable from the instrument before disassembling any part of the instrument.

Location of filter modules and Rsh resistors

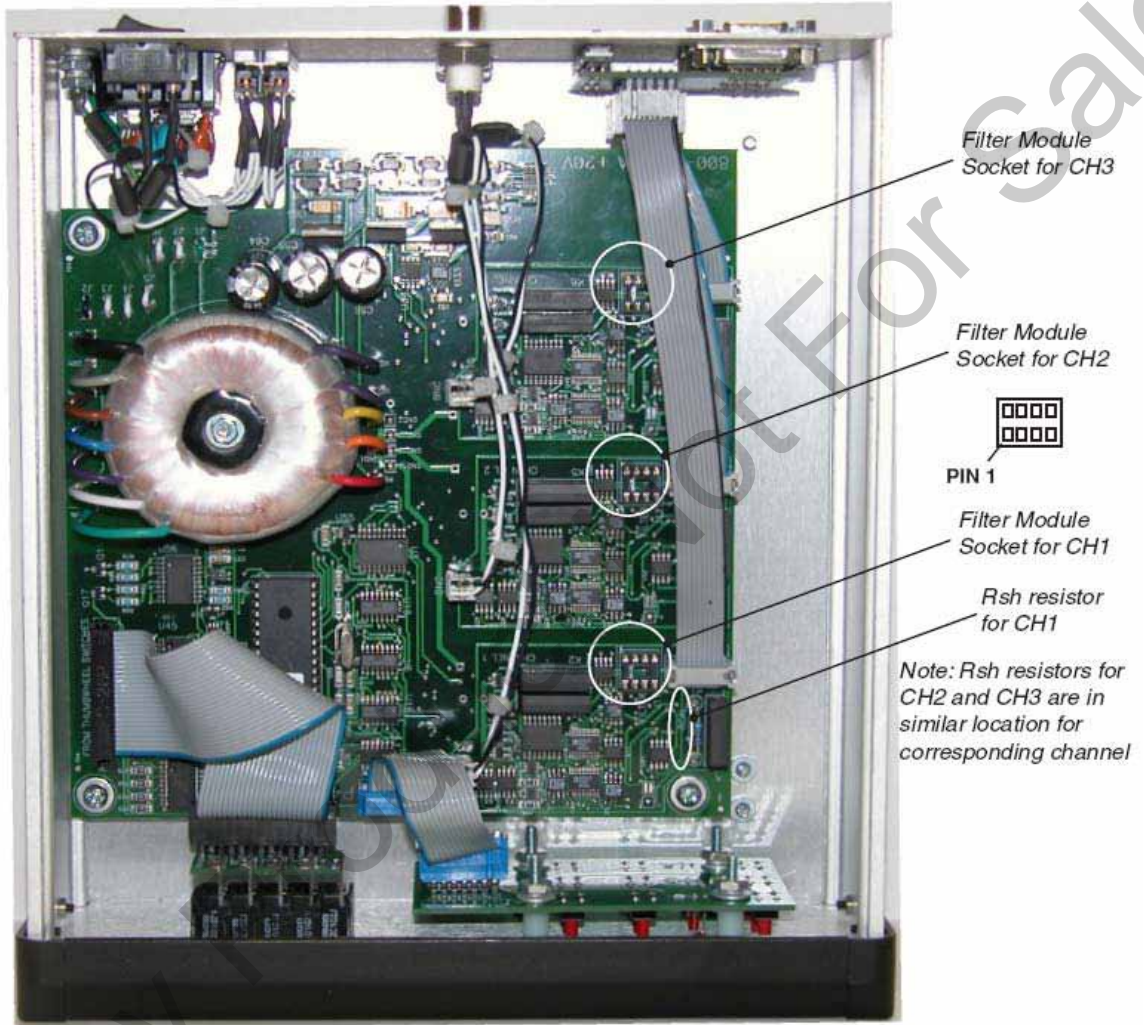

Legacy

Outline dimension

