

INSTRUCTION MANUAL
For Model 2793
ISOTRON SIGNAL CONDITIONER
IM2793, Revision D

TABLE OF CONTENTS

Section 1	General Description
	1.1 Introduction
	1.2 Power Requirements
	1.3 Input and Output Connections
Section 2	Inspection and Set Up
	2.1 Inspection
	2.2 Installation
Section 3	Operation
	3.1 Transducer Connection
	3.2 Output Connections
	3.3 Output Scaling
	3.4 Use with Piezoelectric Transducers
Section 4	Theory of Operation
	4.1 Circuit Content
	4.2 Circuit Operation
Section 5	In Service Recalibration Transducers
	5.1 Test Set Up
	5.2 Gain
	5.3 Frequency Response
	5.4 Noise
	5.5 Status LED Indicator
	5.6 Constant Current Source
Section 6	Performance Specification

SECTION 1

GENERAL DESCRIPTION

1.1 INTRODUCTION

The ENDEVCO Model 2793 16 Channel ISOTRON Signal Conditioner is designed for use with integral electronics piezoelectric transducers or piezoelectric transducers with a Remote Charge Converter (RCC). It supplies power to the transducer from a two wire constant current source. Each channel has a Status LED Indicator to notify the operator if the input conditions are correct or input has an open or short circuit condition. An internal jumper enables the amplifier gain to be set to x1 or x10. Another internal jumper is used to set the constant current supply to 4mA or 10mA.

1.2 POWER REQUIREMENTS

The Model 2793 Signal Conditioner operates from AC voltage with a rear panel selector for 110V to 125V or 200V to 250, 50 to 60Hz. It will also operate from 200V 400Hz aircraft supplies.

1.3 INPUT AND OUTPUT CONNECTORS

The transducer input and the output connectors are electrically isolated BNC type with side connected to circuit common. The input connectors are on the rear panel. The output BNC connectors are on the front panel, also the outputs are available on a rear panel via 25 way "d" connector.

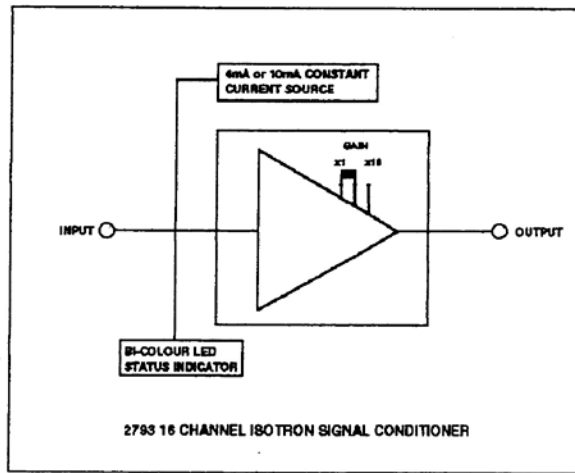

Figure 1

SECTION 2

INSPECTION AND SET UP

2.1 INSPECTION

The 2793 is packed in a protective bag in a primary cardboard carton. This carton is packed in a larger padded shipping carton to prevent in-transit damage. Inspect the contents and any obvious damage should be reported immediately to the carrier.

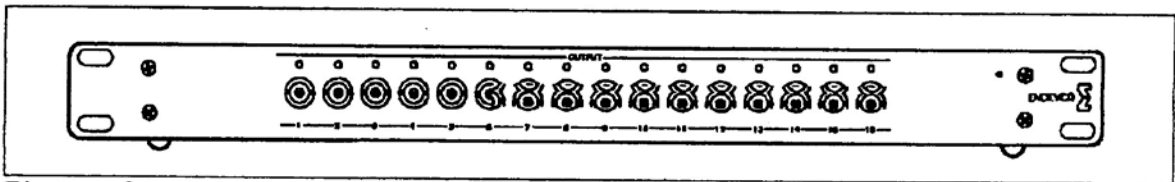

Figure 2

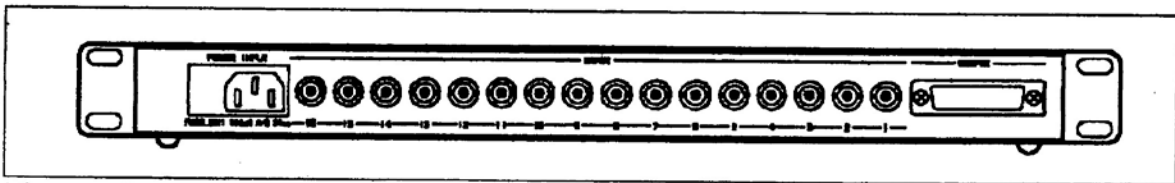

Figure 3

2.2 INSTALLATION

The 2793 is supplied in a standard 19" rack mounting enclosure. For bench use, we recommend that the four self adhesive rubber feet are attached to the bottom panel.

- 2.2.1 Check that the mains power selector is set for the correct mains voltage.
- 2.2.2 Connect the transducer cable to the BNC input connector on the rear panel of the signal conditioner.
- 2.2.3 Connect the monitoring instrument to the BNC output connector on the front panel (or the 25 pin "D" connector on the rear panel).
- 2.2.4 The 2793 is supplied with each channel transducer constant current supply set to 4mA and the gain set to x1.
- 2.2.5 The signal conditioner is now ready for operation.

SECTION 3

OPERATION

3.1 CONNECTIONS

Figures 2 and 3 show the locations of the input and output connectors and the power connector.

3.2 OPERATING INSTRUCTIONS

3.2.1 Connect the Isotron transducer to the channel input and the monitoring instrument to the output. Plug the power cord into the power outlet. The green "Power On" LED indicator at the right hand side of the front panel will light. The "status" bi-color LED of the channel connected will turn green. All other "status" LED's should be off. The 2793 is now ready for use. The gain of each channel is x1 that therefore the output will be transducer sensitivity in mV/engineering unit x1. For an Isotron accelerometer this will be mV/g x1.

If the transducer cable assembly connector has a 10-32 (microdot) connector an EJ21 10-32 to BNC adaptor is available from Endevco.

3.2.2 Figure 4 shown examples of typical ups.

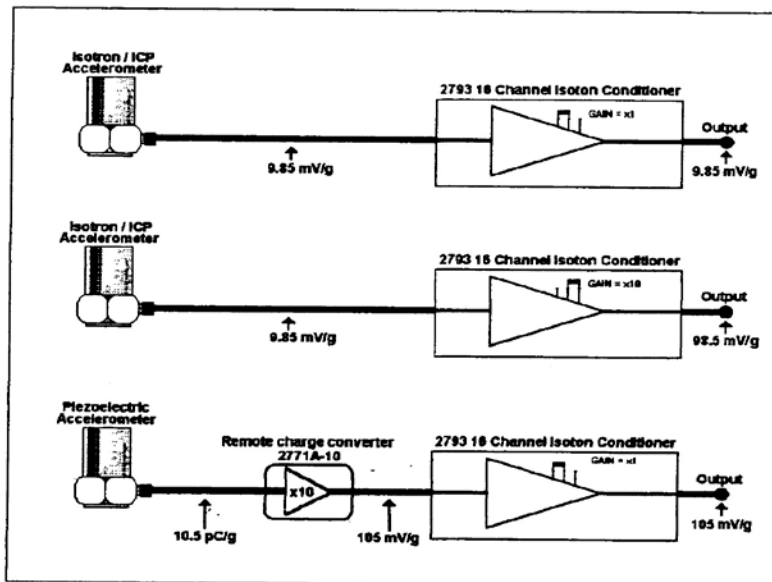

Figure 4

3.3.3 STATUS LED INDICATOR

The "status" LED will indicate green when the transducer is properly connected. If the input is short circuit, the LED will turn red. The LED will turn off when the transducer is removed or if it is open circuit.

3.3.4 OUTPUT CONNECTORS

The signal at the output is the sensitivity of the transducer mV/engineering units (EU) multiplied by the gain setting. For acceleration measurements the EU's are in g's. The output is AC coupled and has a wide frequency response from 1Hz to 30kHz. The output can be connected to a Digital Voltmeter (DVM), Oscilloscope, Signal Analyzer, Data Recorder or Analog to Digital Convertor Board.

3.3.5 USE WITH PIEZOELECTRIC ACCELEROMETERS

Piezoelectric accelerometers can be used with the 2793 in conjunction with an Endevco Model 2771-XX Remote Charge Converter (RCC). The 2771's are constant current powered and therefore are compatible with the 2793. The 2771's are available with gains of x0.1 (2771A-01), x1 (2771A-1), x10 (2771A-10) and x20 (2771A-20).

3.3.6 GAIN SELECTION

Each channel has a jumper LK2 to set the gain to x 1 or x 10. The instrument is supplied with the jumpers set to x 1 gain (unless specifically ordered otherwise). By moving the jumper to pins position 2-3, the gain will be set to x 10, See figure 5.

3.3.7 CONSTANT CURRENT SELECTION

Each channel has its own constant current source and is supplied with it set to 4mA (LK1-1). By moving jumper LK1 to 2-3 will increase the constant current to 10mA. See Figure 5.

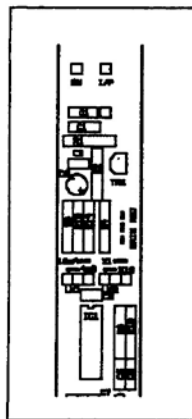

Figure 5

SECTION 4

THEORY OF OPERATION

4.1 CIRCUIT CONTENT

The circuit (Drawings No Y12-2/6) comprises:

- (a) Power supply and constant current drives for Isotron transducers.
- (b) Signal conditioning - buffering, amplification and filtering of the transducer signal.
- (c) "Status" LEDs to indicate when the transducer is properly connected.

4.2 CIRCUIT OPERATION

4.2.1 The circuit diagram Y12-2/6 shown the power supply and one of the 16 identical signal channels.

Each signal channel provides a constant current source to power the transducer (or Remote Charge Converter 2771A-XX when a piezoelectric transducer is to be used), followed by a variable gain amplifier.

A bi-color "status" LED on each channel indicates whether the transducer input is O.K. or whether it has a short circuit or open circuit fault.

The unit "power on" indicator is a green LED located on the upper right of the front panel.

4.2.2 POWER SUPPLY

This is a conventional supply using a split primary shielded toroidal power transformer followed by diode bridges and electrolytic smoothing capacitors. Unregulated +34V and IC regulated -5V are fed to all channels.

To ensure negligible crosstalk between channels, each channel has its own IC signal regulated +25V line.

Each channel's constant current supply is derived from the +25V via the programmable current source TR2 set by resistors R13 or R14 selected by jumper LK1.

4.2.3 SIGNAL CONDITIONING

The transducer signal is coupled Pin 3 of IC1/a, which is configured as a non-inverting amplifier with its output at Pin 1.

The DC level at the transducer input, typically +10V, is suitable for direct coupling of the amplifier, thus avoiding coupling capacitors.

The amplifier gain is selected by a jumper LK2 and can be set to x1 or x10. With the gain set to x1 this stage is a conventional unity gain buffer. With the x10 gain setting, there is provision for adding a gain adjust resistor in parallel to R4, thus the gain can be reduced to a specific value by selecting and fitting the appropriate resistor. Please refer to figure 5. If the channel gain needs to be increased above x10, then resistor R4 should be removed and the appropriate resistor soldered to the gain adjust terminals.

An unusual circuit arrangement has been used for x10 operation. At this gain setting, R5, equal to one ninth of R4, would normally be returned via a decoupling capacitor to signal ground. It is undesirable to use high values for R4 and R5 because of the resulting badly-controlled hf roll-off caused by strays across R4. To obtain the lf response needed, the capacitor would therefore have to be very large. The circuit used requires a much smaller capacitor value.

Here, R5 is returned to the output of a unity gain buffer, the input to which is an lf-filtered form of the transducer input signal. The circuit therefore operates similarly to a conventional non-inverting stage, but the lf filter components R6 and C5 determine the lf cut-off for the amplifier. Since R6 (unlike R5) can be large, a much smaller C5 can be used to obtain the very low cut-off required.

The output of the x1, x10 gain stage is directly coupled to the Sallen and Key low-pass filter comprising R9, R10, C5, C6 and IC2/d. The cut-off frequency can be selected over a wide range by the choice of the passive components, but for a no-overshoot response the equalities $R9 = R10$ and $C5 = C6$ should be retained.

Finally the DC component is removed by output coupling capacitor C7.

4.2.4 LED "STATUS INDICATORS"

LD1 is a green/red bi-colour LED which indicates green if the input socket is connected to a good ISOTRON transducer; indicates red if the transducer/cable is short circuit; is off if no transducer is connected or the transducer/cable is open circuit.

A normal transducer will produce a voltage drop of 8V to 12V when connected to J1, IC1 Pins 1,2,3,5,6,7 will therefore sit between 9.5V and 13.5V, allowing for 1.5V across R3. IC2/a pins 1 & 7 are at -3.5V, TR1 is off, hence the "status" green LED is lit via R19.

With a short-circuit input connection, Pin 3 of IC1/a sits approximately 1.5V above signal ground. Pins 1 and 2 of IC1/a, pins 1, 2 and 3 of IC1/b and Pin 3 of IC2/a are also at + 1.5V. The LED detection circuit will monitor J1 input which is now near to 0V, IC2/a pin 1 will be at -1.2V, pin 7 will be at 20V thus turning on TR1 and turning on the "status" red LED.

With an open circuit input condition, IC2/a pin 7 is at -3.5V, IC2/a pin 1 will sit between 20.5 and 25.5V, turning on TR1 and thus extinguishing the "status" LED.

SECTION 5

IN SERVICE RECALIBRATION PROCEDURES

5.1 TEST SET UP

Make an Isotron transducer simulator as shown in figure 5. (The circuit shown is for a 4mA constant current source, for a 10mA constant current source, change the resistor to 1k Ω .)

Connect the equipment as shown in fig. 5. The green "power on" LED should be illuminated and the channel "status" LED should be green for the channel being tested. The "status" LED's for all other channels should be off.

Set the sinewave oscillator frequency to 100 Hz and adjust the amplitude to 500 mV rms.

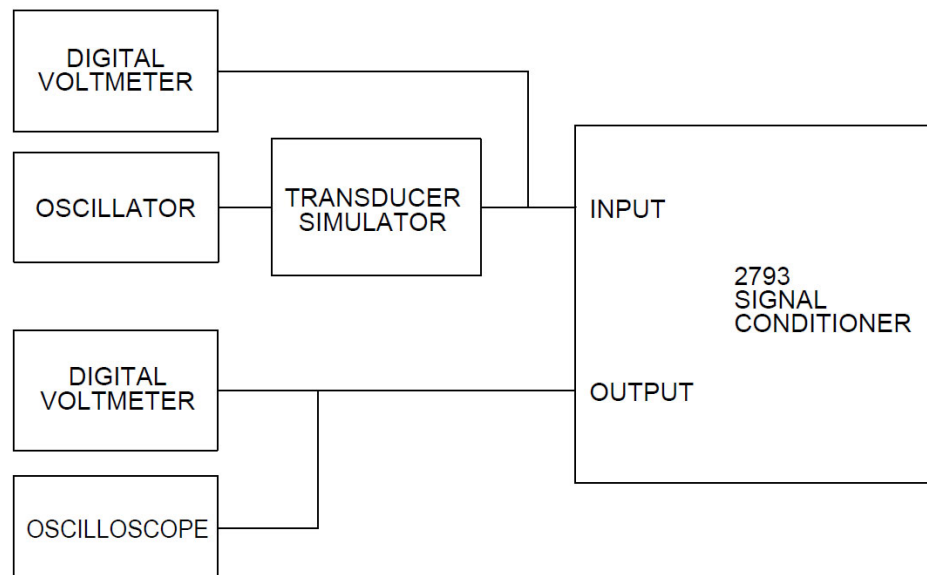

Figure 6

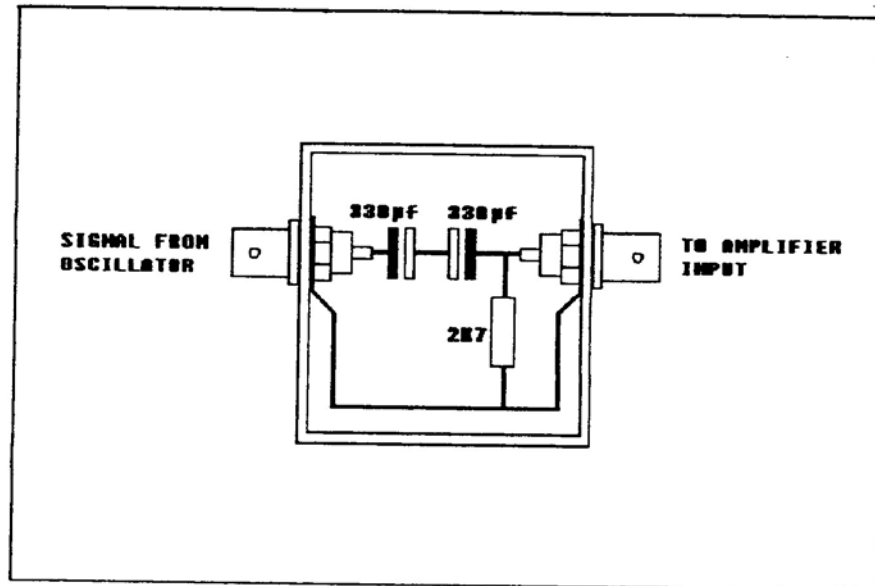

Figure 7

5.2 GAIN

Check that the output of the 2793 channel is 500 mV rms $\pm 1\%$.

Observe the waveform and check that there is no visible distortion or clipping. Increase the input value and confirm that clipping does not occur below 3.535V rms at the output.

5.3 FREQUENCY RESPONSE

Adjust the amplitude for an output of 5.00V rms at 100 Hz, Measure and record the input voltage to the 2793. This will be the reference input level and should be maintained at all frequencies.

Measure and record the 2793 output at frequencies between 2 Hz the 20 kHz. The frequency response tolerance should be within $\pm 5\%$ over the frequency range.

5.4 NOISE

Remove the input signal and connect a 100 Ω resistor across the input of the transducer simulator. With the gain set to x10, the noise at the output should not exceed 400 μ V rms.

5.5 STATUS LED INDICATOR

Connect a short circuited BNC plug to the channel input of the 2793. Within 2 seconds the LED should turn from green to red. Disconnect the S/C BNC and the LED should return to green.

5.6 CONSTANT CURRENT SOURCE

Connect an ammeter between the transducer simulator and the channel input of the 2793. The current should be $4\text{mA} \pm 10\%$.

SECTION 6

PERFORMANCE SPECIFICATION

6.0 DESCRIPTION

The ENDEVCO® Model 2793 16 Channel ISOTRON® Signal Conditioner is a compact multi-channel signal conditioner for use with integral electronic piezoelectric transducers. It supplies power to the transducer from a constant current source. Each channel has a bi-colour LED "status" indicator to notify the operator that the transducer input conditions are O.K. or that there is an open or short fault condition.

6.1 KEY FEATURES

- * 16 channel signal conditioner for ISOTRON accelerometers or remote charge convertors
- * Wide frequency range 1Hz to 30kHz
- * 1.75" high 19" rack mount configuration
- * Wide dynamic range
- * Jumper selectable gain of 1 or 10
- * Jumper selectable constant current supply 4mA or 10mA

6.2 INPUTS

- | | | |
|-------|-------------------------------|---|
| 6.2.1 | Type | Single-ended compatible with constant current systems using to wire remote electronics. |
| 6.2.2 | Input Impedance | 20k Ω minimum. |
| 6.2.3 | Transducer Excitation Current | 4mA or 10mA \pm 10%, selected by internal jumpers |
| 6.2.4 | Compliance Voltage | 20V \pm 5%. This voltage is the sum of the quiescent transducer voltage and the transducer output voltage. |
| 6.2.5 | LED Indicator | The LED will light green if the transducer is connected normally. The LED will turn red, if the transducer or cable is shorted. The LED will turn off when the transducer is removed, of the cable is open. |

6.3 OUTPUTS

6.3.1	Type	Single ended compatible with one side connected to circuit ground.
6.3.2	Output Impedance	10 Ω maximum in series with at least 40 μ F
6.3.3	Max. Linear Output Voltage	10 volts pk-pk (3.535 V rms) or greater
6.3.4	Maximum Linear Output Current	2.0 mA pk-pk or greater

6.4 TRANSFER CHARACTERISTICS

6.4.1	Gain	1 or 10 selectable by internal jumper
6.4.2	Accuracy	+1.5%
6.4.3	Frequency Response	Flat within its bandwidth. The gain at the upper and lower cutoff frequencies are 5% lower than the gain at 1000 Hz.
6.4.4	Lower Cut-off Frequency	1 Hz maximum
6.4.5	Upper Cut-off Frequency	30 kHz minimum
6.4.6	Amplitude Linearity	1% of reading from best fit straight line approximation to the curve of output vs input for signals of full scale or less.
6.4.7	Residual Noise	0.4mV rms for gain of 1.0, 2mV rms maximum for gain 10 within a 30kHz bandwidth.
6.4.8	Total Harmonic Distortion	Less than 1% maximum for signal of full scale or less.
6.4.9	Crosstalk	20.0mV rms maximum RTO or 1.0mV rms RTI whichever is greater. With one channel operating at full scale and adjacent channel with 250 Ω shunt resistor at the input.

6.5 POWER

6.5.1 Line Voltage 100/120/220/240V AC 50 to 60Hz selectable

6.6 PHYSICAL

6.6.1 Dimensions 19" rack mounting, 1.73h X 9.45d X 19w
(44 x 240 x 483 mm)

6.6.2 Weight 3.97 (1.8 kg)

6.6.3 Connectors
Output BNC
Input BNC
Output 25 pin "D"

6.7 ENVIRONMENTAL

6.7.1 Temperature
Operating 0 to +50°C
Non-operating -54 to +85°C

6.7.2 Accessories

Power Cord
Instruction Manual

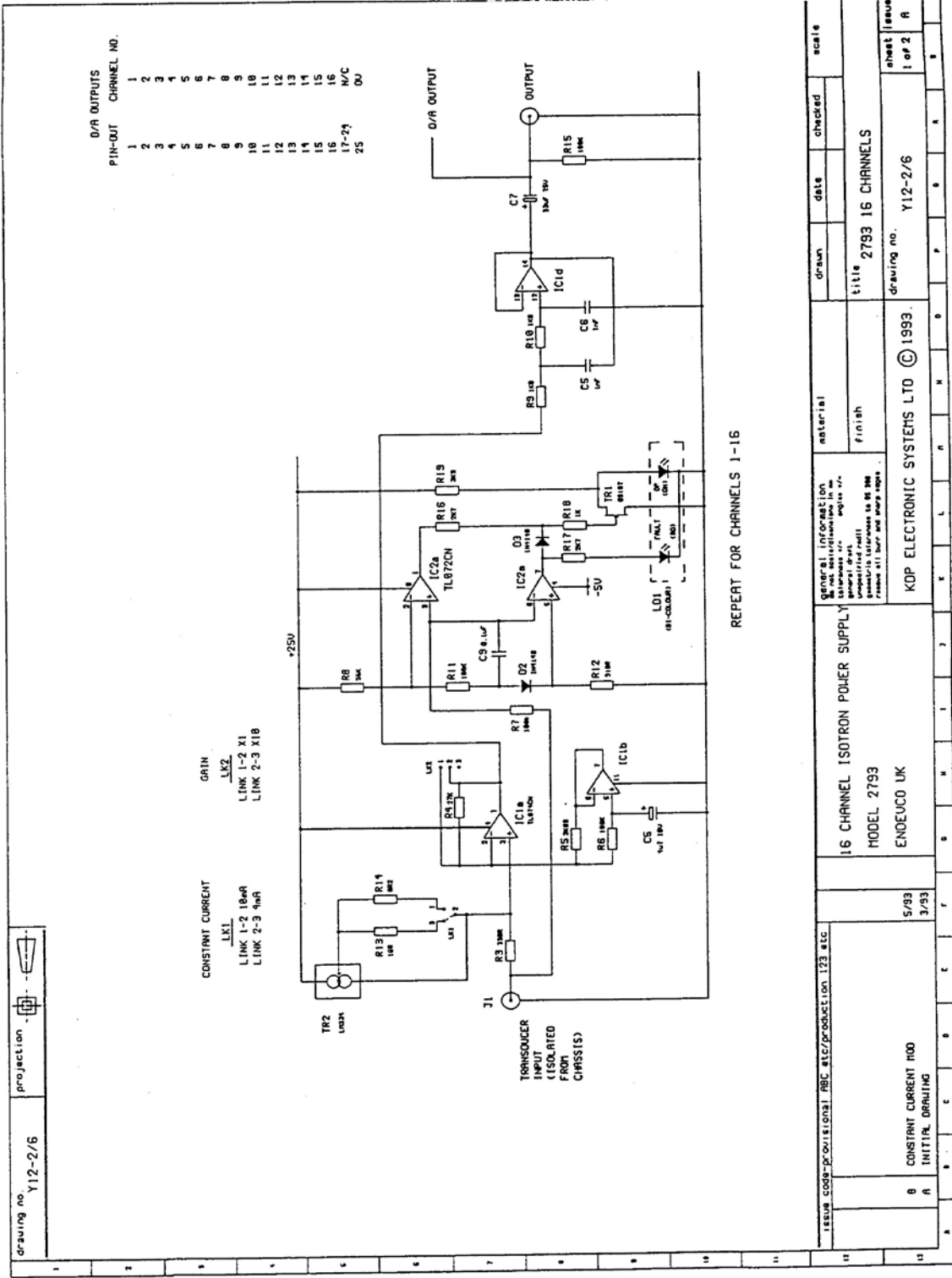

drawing no. Y12-2/6



ISSUE CODE		PROVISIONAL REC. DATE/PRODUCTION 123 etc		GENERAL INFORMATION		MATERIAL		DRAWN		DATE		CHECKED		SCALE	
B		CONSTANT CURRENT MOD INITIAL DRAWING		16 CHANNEL ISOTRON POLE SUPPLY		16 CHANNEL ISOTRON POLE SUPPLY		2793		2793 16 CHANNELS					
A				MODEL 2793		FINISH		2793		Y12-2/6				1 OF 2	
				ENDEUVO UK		KDP ELECTRONIC SYSTEMS LTD © 1993		drawing no.						sheet issue	
				5/83										A	
				3/93										R	